



Electric



Gas



Propane  
Option

# CC100 Single Head Floor Grinder

10"/12" Head Capacity

Push

**Grinds, Cleans, Levels  
and Smooths Bumps  
and Uneven Areas  
Quickly**

### Features & Benefits

- Remote throttle
- 2" dust port opening
- Single grease point
- Steel box frame
- Adjustable handles
- Lifting handles
- Adjustable wheel location for added grinding strength
- Variety of power options: gas, electric, hydraulic or propane fitting
- Single head for fast, aggressive grinding
- Greasing points are easily accessible
- Electric models include starter box

CC110H

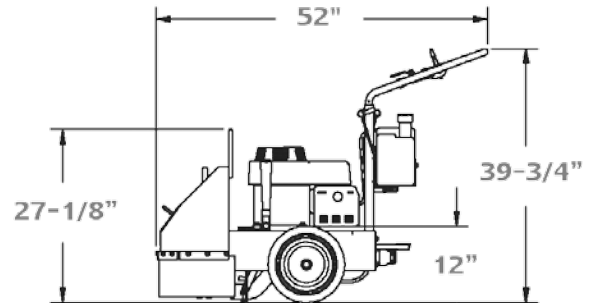

CC175E



CC114HY

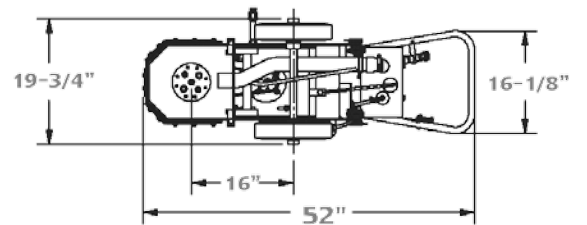

## CC100 SINGLE HEAD FLOOR GRINDER

Model #	Engine/Motor Make	Engine/Motor Power	Power Source	Part #	Cat #	Head Capacity	Product Weight (lbs)
CC102E1	Baldor	2 HP - 1PH, 115V or 230V	Electric	5800539	48551	10"/12"	370
CC110H	Honda GXV390	10.2 HP	Gas	5800527	47385	10"/12"	320
CC175E1	Baldor	7.5 HP - 1PH, 230V	Electric	5800529	48552	10"/12"	355
CC175E3	Baldor	7.5 HP - 3PH, 230V	Electric	5800530A	95042	10"/12"	370
CC175E3	Baldor	7.5 HP - 3PH, 460V	Electric	5800530B	94981	10"/12"	370
CC114HY	Danfoss	14 HP - 2500PSI, 12 GPM	Hydraulic	5800532	48553	10"/12"	220
NOTE: Floor Grinders comes with one 65lb weight ballast (*excludes Model # CC102E1)							
Optional Second weight available				2501047	47017	---	---

### Propane Kit for CC113H

Part # Cat #

6040322 10156

### Required Bracket

6043551 14589