

CC800M Block Saw



Gas



Electric



14" Capacity

Table Top or Stand Kit

Features & Benefits

- 24" blade cuts a 10" block in a single pass
- Variety of power options
- Stay level blade guard and enclosed blade shaft
- Replaceable cart travel rails
- Durable 3/16" steel frame
- Includes water pump
- Easy rolling 16" x 25" aluminum cutting cart/tray with vulcanized rubber coated non-slip top
- Large capacity, deep tapered water tray
- Foot pedal controlled operating head leaves the operators hands free to guide material
- Hand wheel for quick and easy blade cutting depth adjustment
- Enclosed cart wheels prevent damage
- Forklift opening for easy transport
- 2 V-belts promote efficient delivery of power to the blade
- Open back design for rip cutting longer materials
- Counterbalanced stay level blade guard assures the head is parallel to the cutting cart at all times

Specifications

Maximum Depth of Cut:	8" with 20" blade, 10" with 24" blade
Arbor Diameter:	1"
Blade Shaft Bearings:	Flange block ball bearings
Blade Shaft Drive:	2 premium grip notch v-belt
Blade Raise/Lower:	Counterbalanced, spring tensioned head pivots on two 1" flange block bearings
Blade Coolant:	Dual spray tubes, pump fed (electric models), garden hose connection (gas models)
Air Filter:	3-stage cyclone (gas models)
Fuel Capacitor:	1 gallon (gas models)
High Temp Shut-off:	Included (electric models)
Starter:	Recoil on gas models, capacity on electric models

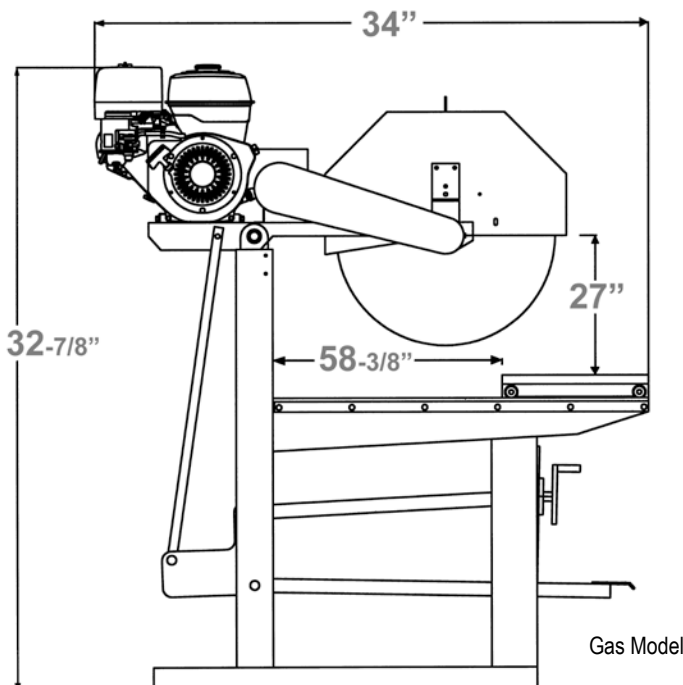

CC800M BLOCK SAW

Model #	Motor/Engine Make	Motor/Engine Power	Power Type	Part #	Cat #	Blade Capacity	Product Weight (lbs)
CC850ME1-20	Baldor	5 HP - 1PH, 110V	Electric	5800540	46820	20"	470
CC850ME3-20	Baldor	5 HP - 3PH, 230V	Electric	5800541A	96416	20"	550
CC850ME3-20	Baldor	5 HP - 3PH, 460V	Electric	5800541B	18533	20"	500
CC875ME1-20	Baldor	7.5 HP - 1PH, 110V	Electric	5800542	47664	20"	525
CC875ME3-20	Baldor	7.5 HP - 3PH, 230V	Electric	5800544A	96015	20"	510
CC875ME3-20	Baldor	7.5 HP - 3PH, 460V	Electric	5800544B	96336	20"	515
CC875ME1-24	Baldor	7.5 HP - 1PH, 110V	Electric	5800543	47630	24"	530
CC875ME3-24	Baldor	7.5 HP - 3PH, 230V	Electric	5800545A	97240	24"	550
CC875ME3-24	Baldor	7.5 HP - 3PH, 460V	Electric	5800545B	97000	24"	550
CC808MH-20	Honda GX270	8 HP, 14.1 torque (lbs.-ft.)	Gas	5800546	47024	20"	460
CC809ML-20	Lifan LF177F	9 HP	Gas	5801107	33971	20"	576
CC811MH-20	Honda GX390	11 HP, 19.5 torque (lbs.-ft.)	Gas	5800547	47047	20"	485
CC811MH-24	Honda GX390	11 HP, 19.5 torque (lbs.-ft.)	Gas	5800548	47046	24"	485

* Blade not included

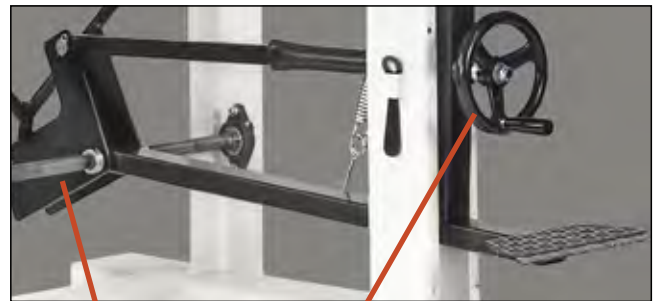

Pedal mechanism is spring loaded, giving you more control of your cut

Hand wheel makes it easy to adjust your cutting depth

Foot pedal leaves the operator's hands free which helps safety issues when cutting



We offer 20" and 24" masonry blades to maximize your productivity when using the CC800M or any of the other masonry saw models.

Available in 5 different quality grades.